

THE NEXT GENERATION OF MIXING

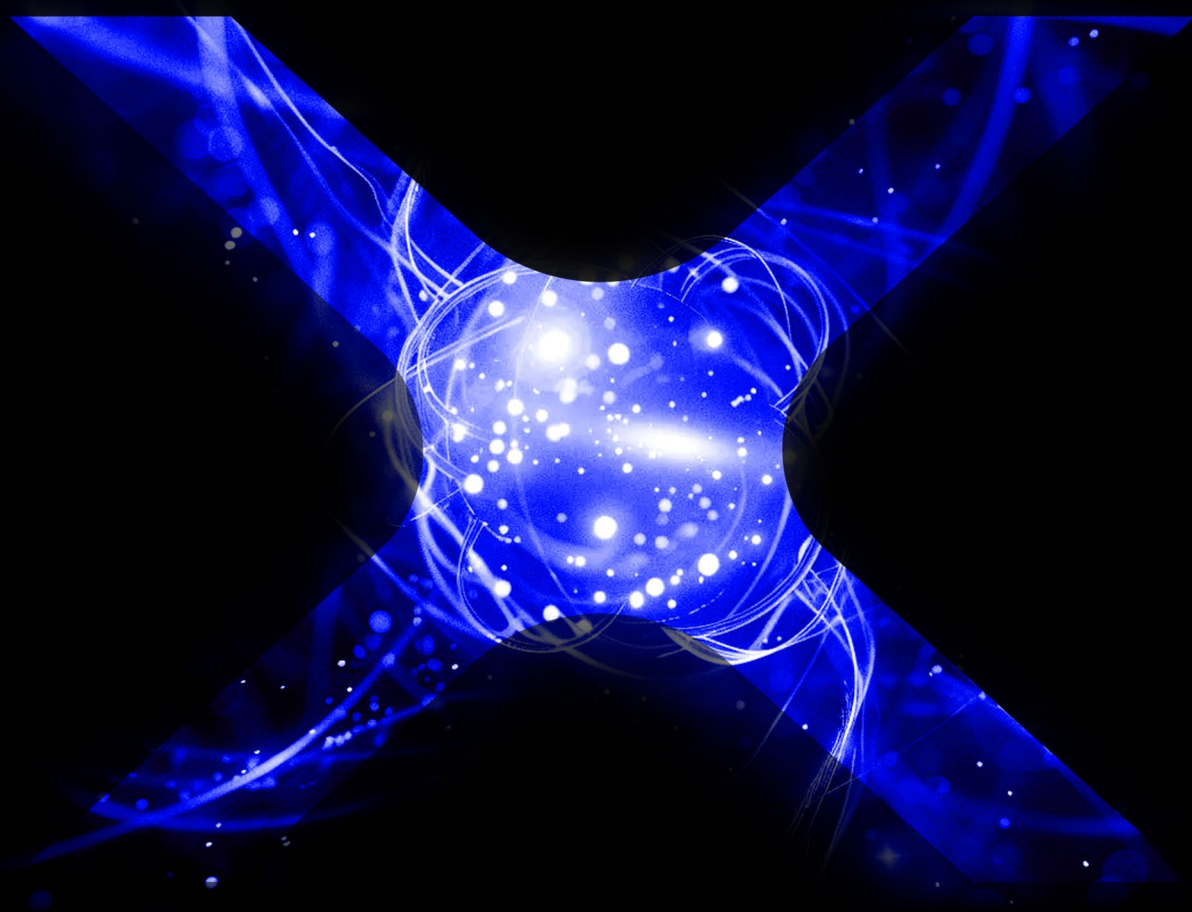

QuantumX

# THE FUTURE OF ADVANCED PROCESSING HAS ARRIVED

01



# There wa

There was a time when industrial mixing was viewed as a relatively simple operation. Powders entered a vessel, an agitator rotated, and material exited “blended.” For many conventional products, that approach was enough.

**That era is over.**

Modern manufacturing has evolved into something far more demanding. Today’s processors are no longer simply combining ingredients. They are engineering performance. They are developing products whose functionality, stability, consistency, and value are determined not only by formulation, but by how those formulations are processed.

This shift has transformed the role of mixing entirely.

In pharmaceuticals, nutraceuticals, specialty chemicals, advanced foods, cosmetics, energy materials, nanotechnology, and defense-related applications, the mixer has become more than a blending machine. It has become a controlled process environment where powders are dried, reactions are activated, solvents are removed, granules are formed, particles are conditioned, moisture is controlled, and material behavior itself is transformed.

This is precisely why QuantumX™ Vacuum Mixers & Dryers were created. QuantumX was not designed to compete in the world of ordinary mixers. It was engineered for manufacturers operating in environments where process control determines product value. Our systems are built around a simple understanding: The future of advanced manufacturing belongs to companies capable of controlling not only ingredients—but atmosphere, temperature, vacuum, particle behavior, and thermal transformation itself.

## That is what QuantumX delivers.

## WHY VACUUM PROCESSING CHANGES EVERYTHING

# as a time

Most manufacturers underestimate how profoundly vacuum changes processing behavior.

Under atmospheric conditions, moisture and solvents evaporate only after reaching relatively high boiling temperatures. For sensitive materials, this creates a dangerous compromise. Higher temperatures may accelerate drying, but they may also damage the product itself. Proteins may denature. APIs may degrade. Flavor compounds may disappear. Powders may discolor, oxidize, or collapse structurally. Reactive materials may behave unpredictably.

### **Vacuum changes this relationship completely.**

By reducing pressure inside the processing chamber, the boiling point of liquids decreases dramatically. Moisture and solvents can now evaporate at substantially lower temperatures, allowing the process to become gentler, faster, and significantly more controlled.

But this is only the beginning of what vacuum processing makes possible.

### **Inside a properly engineered vacuum environment:**

- thermal transfer becomes more efficient,
- oxidation can be minimized,
- entrained air can be removed,
- solvent recovery becomes easier,
- particle conditioning improves,
- reactions become more controllable,
- and sensitive materials can be processed with far greater stability.

In many advanced applications, vacuum processing is not simply beneficial. It is the difference between an acceptable product and a premium one.

A poorly designed vacuum system may still remove moisture. But an intelligently engineered vacuum process environment can preserve chemistry, stabilize particle behavior, improve product functionality,

shorten process time, and create a level of consistency that conventional systems struggle to achieve.

**This distinction is where  
QuantumX separates itself.**



## Powder processing is far more complex than many realize.

Inside every batch, countless interactions occur simultaneously:

- particles collide,
- moisture migrates,
- heat transfers,
- air becomes entrapped or released,
- agglomerates form or break apart,
- reactions accelerate or stabilize,
- and material properties continuously evolve.

A conventional mixer may move material through a vessel, but movement alone does not create process control.

QuantumX systems are engineered around the understanding that successful vacuum processing requires control of the entire environment in which transformation occurs.

**Inside a QuantumX Vacuum Mixer & Dryer, multiple mechanisms are intentionally balanced.**

Continuous agitation exposes fresh particle surfaces to both thermal energy and vacuum conditions. This dramatically improves evaporation efficiency while preventing localized overheating. As the material circulates, moisture migrates outward from the interior of the particles while vacuum lowers the energy required for evaporation.

At the same time, controlled thermal energy is introduced through jacketed vessel walls and, in many configurations, through heated agitation components as well. This creates a highly uniform thermal field where heat is distributed deliberately rather than aggressively.

The importance of this cannot be overstated.

Many vacuum dryers fail not because they cannot create vacuum, but because they fail to create uniform thermal and particle exposure conditions. Some regions of the batch dry too quickly while others remain wet. Hotspots develop. Agglomerates form. Product degrades. Drying curves become inconsistent. Scale-up becomes unpredictable.

**QuantumX systems are specifically engineered to eliminate these issues through:**

- controlled particle movement,
- optimized agitator geometry,
- engineered residence behavior,
- uniform thermal transfer,
- and intelligent atmosphere management.

This is not simply mixing under vacuum. This is engineered transformation under controlled process conditions.

DESIGN

# WHY POWDERS BEHAVE DIFFERENTLY UNDER VACUUM

# 04



One of the most misunderstood aspects of vacuum processing is how dramatically particle behavior changes once pressure is reduced.

Powders that flow freely under atmospheric conditions may suddenly become cohesive under vacuum. Certain materials begin releasing entrained gases. Some become electrostatically active. Others experience rapid moisture migration that changes their physical structure during processing.

At elevated temperatures, these effects become even more pronounced.

#### Particles may:

- soften,
- partially melt,
- form liquid bridges,
- collapse structurally,
- or agglomerate unpredictably.

This is why advanced vacuum processing cannot rely on simple agitation alone. The system must be engineered around how the material itself behaves throughout the thermal and atmospheric cycle.

QuantumX systems are designed precisely for this challenge.

#### The relationship between:

- agitator geometry,
- rotational speed,
- thermal input,
- vacuum intensity,
- fill level,
- and residence time

...is carefully engineered to maintain stable particle behavior throughout the process.

#### This allows QuantumX systems to:

- prevent unwanted agglomeration,
- maintain product mobility,
- improve drying consistency,
- preserve particle integrity,
- or intentionally promote controlled granulation when desired.

**That level of control is what separates high-performance vacuum processing from basic vacuum drying.**

## THE HIDDEN COST OF UNEVEN DRYING

# 05

Many manufacturers discover too late that uneven drying creates problems far beyond residual moisture itself.

**When moisture removal becomes inconsistent:**

- powders may cake,
- flow behavior changes,
- particle strength varies,
- downstream filling becomes unstable,
- dissolution performance shifts,
- and shelf life may suffer.

In pharmaceutical applications, inconsistent drying may affect tablet compression and active distribution. In protein systems, it may alter hydration behavior and mouthfeel. In specialty chemicals, it may destabilize reactions or compromise performance. In battery materials, residual moisture can directly affect conductivity and long-term stability.

The most dangerous part is that these problems are often subtle. The product may appear visually acceptable while still carrying hidden instability within the particle structure itself.

**QuantumX systems are engineered to eliminate these inconsistencies by ensuring that:**

- thermal exposure remains uniform,
- particle movement remains active,
- moisture migration remains controlled,
- and the entire batch experiences the same process environment.

This creates not only better drying performance, but more predictable material behavior downstream.

And in advanced manufacturing, predictability is power.

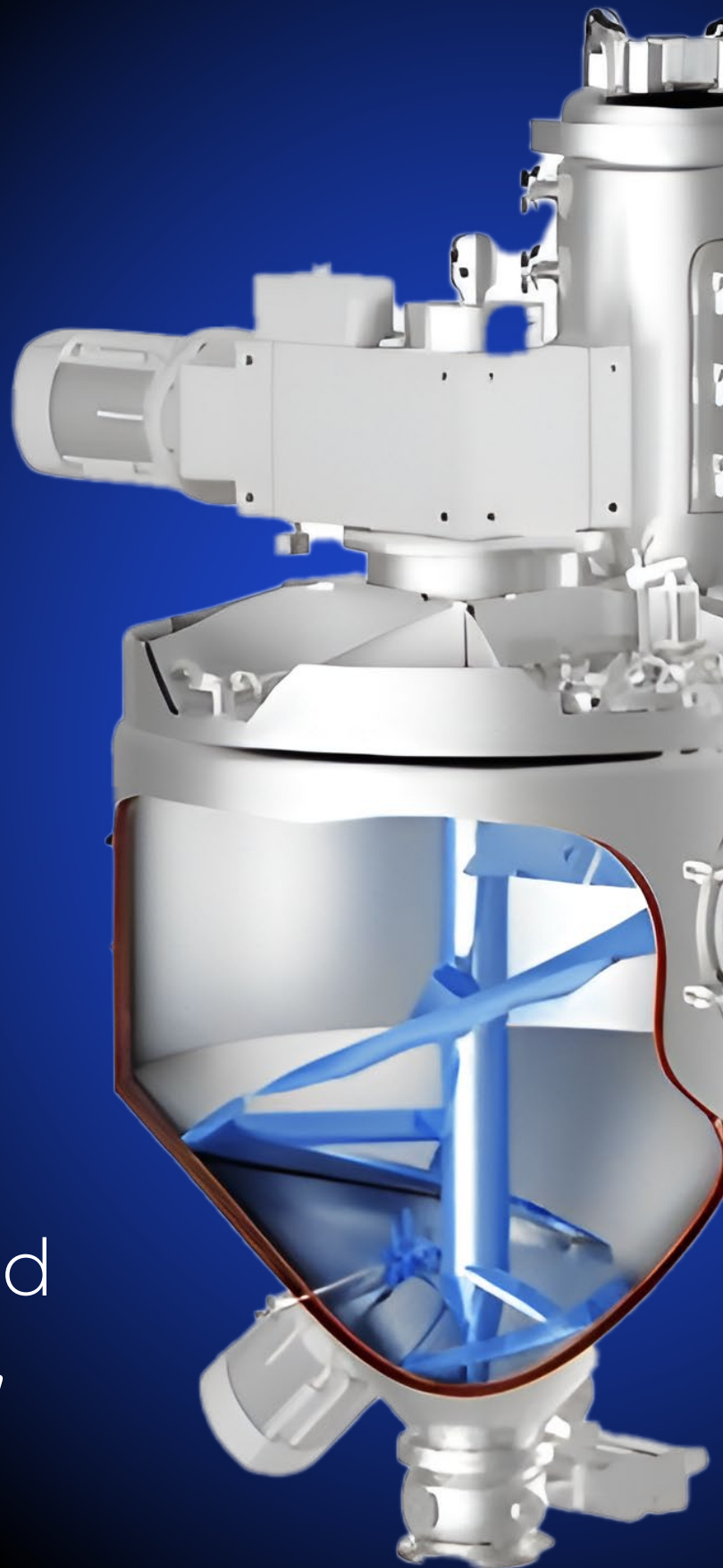

## HIGH TEMPERATURE PROCESSING – UP TO 450°C AND BEYOND

Some materials require more than gentle vacuum drying.

**Certain applications demand high-temperature processing environments capable of supporting:**

- thermal activation,
- calcination support,
- polymer modification,
- carbonization,
- controlled decomposition,
- sterilization,
- or high-temperature reaction chemistry.

QuantumX Vacuum Mixers & Dryers can be engineered for temperatures reaching 450°C and beyond while maintaining precise process control throughout extended operating cycles.

At these temperatures, powders and materials often become highly unstable. Certain materials soften. Others release volatile compounds. Some begin forming severe agglomerates or sticky transition zones. Heat-sensitive regions may degrade while cooler regions remain underprocessed.

**This is where true process engineering becomes critical.**

**QuantumX systems are specifically developed to maintain:**

- thermal stability,
- controlled particle movement,
- atmosphere integrity,
- and process consistency

...even under extremely demanding thermal conditions.

**This capability is especially valuable in:**

- advanced energy materials,
- specialty ceramics,
- battery compounds,
- nanotechnology,
- carbon materials,
- specialty chemicals,
- and defense-related processing.

The objective is not simply surviving extreme temperatures. The objective is maintaining process precision while transformation occurs.





## UNDERSTANDING AGGLOMERATION & PARTICLE ENGINEERING

# 07

Agglomeration is not inherently good or bad.

**In some applications, controlled agglomeration creates tremendous value. It may improve:**

- flowability,
- wettability,
- compressibility,
- bulk density,
- dissolution,
- and handling performance.

In other applications, uncontrolled agglomeration becomes a major processing failure.

**The challenge is that vacuum, heat, moisture migration, and particle movement all influence agglomeration simultaneously.**

This is where many systems struggle.

**Conventional equipment often creates:**

- localized overwetting,
- stagnant thermal regions,
- poor particle circulation,
- or uneven shear distribution,

...leading to hard lumps, inconsistent granules, or unstable drying behavior.

QuantumX systems are engineered to actively manage particle interaction throughout the process cycle.

**Depending on the application objective, the system may:**

- encourage controlled granulation,
- maintain fluidized particle movement,
- continuously deagglomerate material,
- or preserve highly fragile particle structures.

**This level of control becomes especially important in:**

- pharmaceutical granulation,
- protein instantization,
- specialty powder conditioning,
- advanced battery materials, and high-value chemical processing.

Because ultimately, advanced processing is not simply about moving powders. It is about engineering particle behavior itself.

## MIXING UNDER PRESSURE – WHEN THE PROCESS DEMANDS MORE

# 08

**While vacuum processing plays a critical role in modern manufacturing, many advanced applications also require operation under pressure.**

**Pressure environments may be used to:**

- accelerate reaction kinetics,
- improve gas-solid interaction,
- enhance penetration behavior,
- stabilize thermal environments,
- or support controlled atmosphere chemistry.

**QuantumX systems can be engineered for:**

- vacuum operation,
- positive pressure operation,
- or dual vacuum/pressure capability,

...allowing manufacturers to process materials within highly controlled atmospheric conditions.

**This creates exceptional flexibility for:**

- specialty chemicals,
- reactive materials,
- advanced ceramics,
- nanotechnology,
- and energy-related processing.

**When pressure and vacuum capability are integrated into a single process platform, the manufacturer gains the ability to:**

- dry,
- react,
- coat,
- granulate,
- condition,
- and thermally transform materials

...inside one engineered process environment.

That level of integration is one of the defining characteristics of next-generation manufacturing.





Many advanced thermal processes require far more than short production cycles.

**Certain materials demand:**

- staged heating profiles,
- extended vacuum exposure,
- slow moisture migration,
- long-duration reactions,
- or continuous atmosphere control over many hours or even days.

**QuantumX systems are engineered specifically for these demanding environments.**

**Vacuum integrity, thermal stability, agitator performance, and atmosphere management are all designed for long-duration operational consistency. This is especially critical in:**

- battery material processing,
- specialty chemical manufacturing,
- advanced ceramic applications,
- nanotechnology,
- and pharmaceutical intermediates.

The goal is not simply continuous operation. The goal is continuous process precision.



Different materials require different process environments. That is why **QuantumX** offers a comprehensive portfolio of vacuum processing systems designed around how powders, granules, slurries, and advanced materials actually behave during thermal and atmospheric processing.

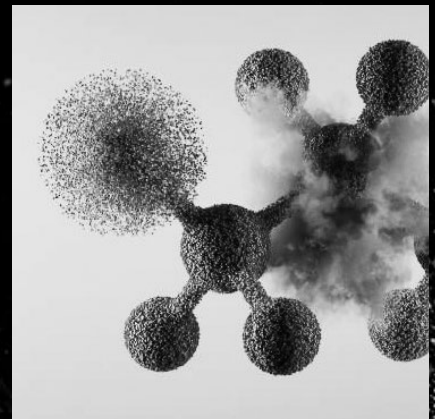
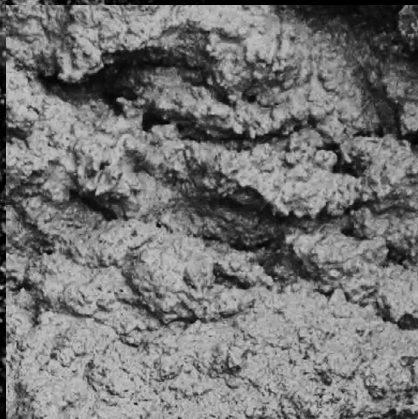

# QuantumX

was designed for this reality from  
the beginning.

## HORIZONTAL VACUUM MIXERS & DRYER

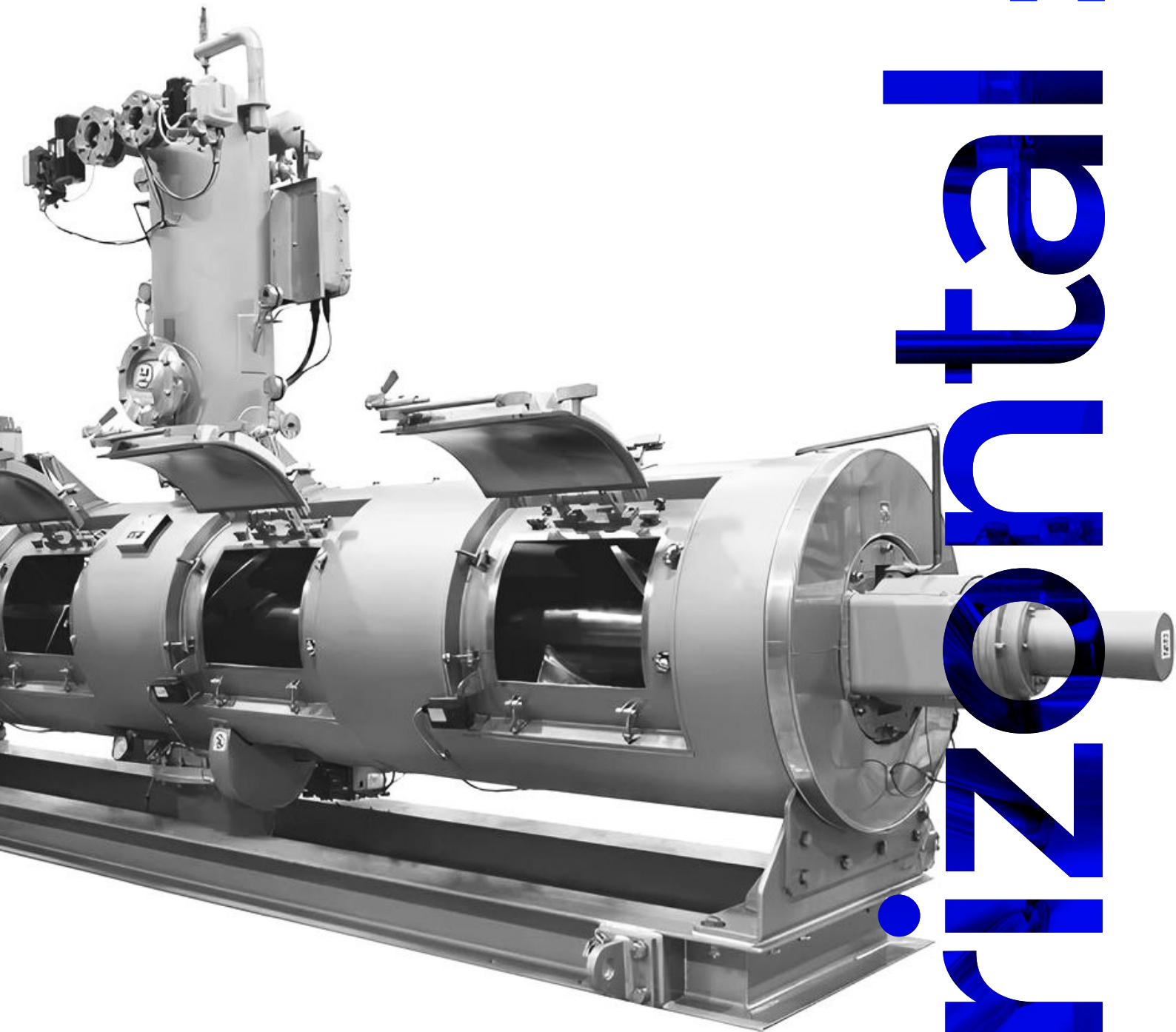

**Horizontal systems are widely selected for:**

- high-capacity processing,
- aggressive thermal transfer,
- rapid mixing,
- and demanding multiphase applications.

**Their geometry allows excellent heat-transfer exposure while supporting highly dynamic product movement.**



**QuantumX Vacuum Ribbon Mixers & Dryers combine highly efficient convective mixing with vacuum-assisted thermal processing in a versatile and scalable platform.**

The ribbon agitators continuously move material both radially and axially throughout the vessel, promoting highly uniform circulation and broad particle exposure to thermal surfaces.

**These systems are ideal for:**

- food ingredients,
- nutraceutical powders,
- specialty chemicals,
- thermal conditioning,
- and large-scale drying operations.

**Optional features may include:**

- heating & cooling jackets,
- pressure capability,
- solvent recovery systems,
- atomized liquid addition,
- and CIP/WIP configurations.



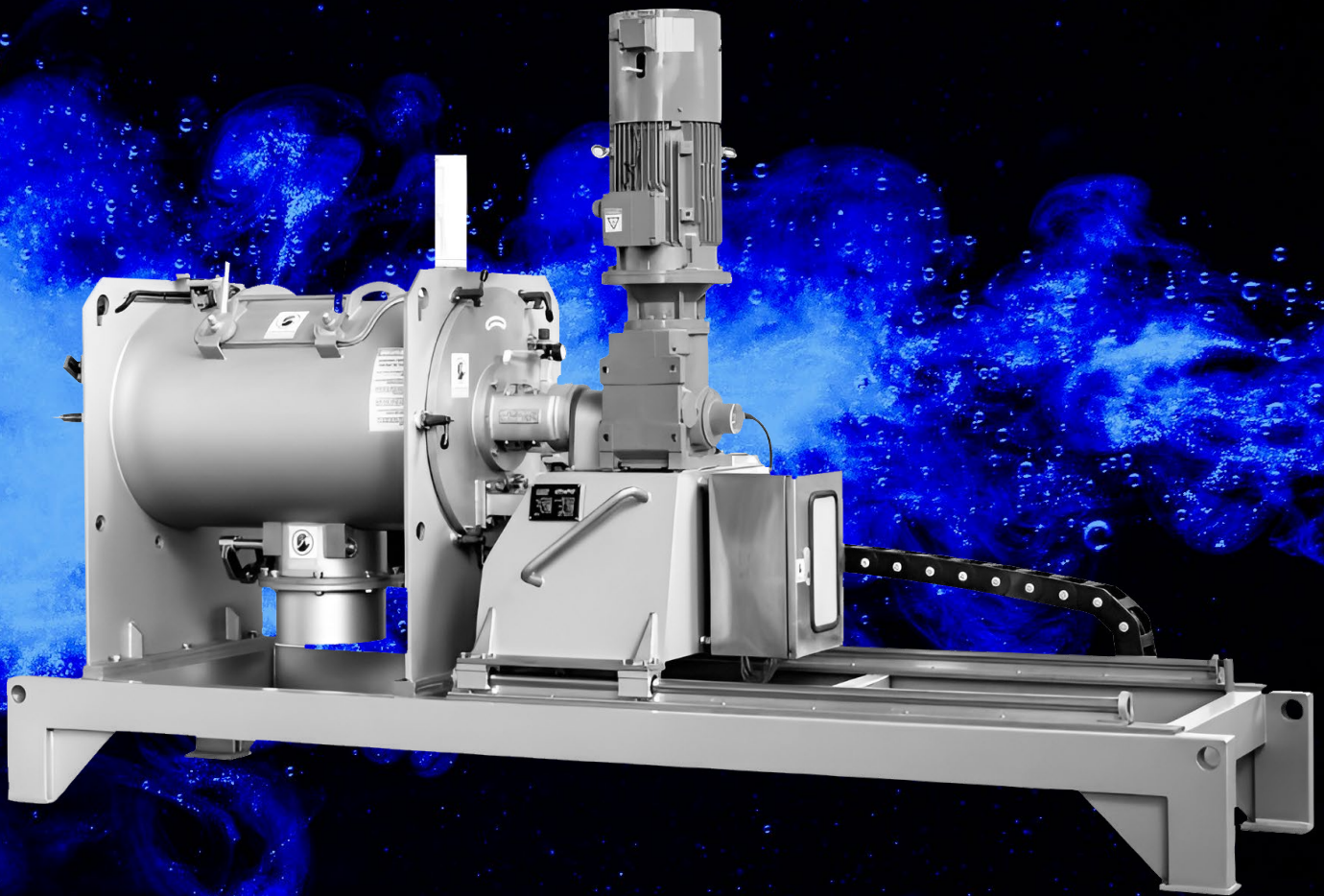

## QuantumX Vacuum Plow Mixers & Dryers are engineered for highly dynamic fluidized-zone processing.

The plow geometry mechanically accelerates particles into a three-dimensional fluidized mixing state where the product continuously separates from the vessel wall, dramatically increasing exposed surface area and improving both thermal transfer and drying efficiency.

### Optional high-speed choppers:

- eliminate agglomerates,
- improve particle conditioning,
- support granulation,
- and stabilize difficult thermal applications.

### These systems excel in:

- cohesive powders,
- difficult drying applications,
- advanced thermal processing,
- and high-intensity material transformation.

## VACUUM PADDLE MIXERS & DRYERS

# 14

### QuantumX Vacuum Paddle Mixers & Dryers provide highly efficient but gentler processing environments.

Their overlapping paddle geometry creates complete vessel coverage while maintaining lower shear characteristics ideal for:

- fragile materials,
- heat-sensitive products,
- pharmaceutical powders,
- specialty foods,
- and nutraceutical applications.

The systems provide broad thermal exposure while preserving particle integrity throughout the process cycle.





**QuantumX Vacuum High-Speed Granulators & Dryers are engineered for integrated granulation and drying operations where particle engineering is critical.**

**These systems enable:**

- rapid binder distribution,
- controlled granule growth,
- vacuum-assisted drying,
- and highly repeatable process environments.

**They are particularly valuable in:**

- pharmaceutical granulation,
- nutraceutical processing,
- specialty chemical manufacturing,
- and functional powder engineering.

## VACUUM FLUIDIZED ZONE MIXERS

# 16

QuantumX Vacuum Fluidized Zone Mixers are engineered to maintain highly active particle movement throughout the process cycle.

By maximizing particle exposure, these systems improve:

- thermal uniformity,
- drying efficiency,
- granulation consistency,
- and coating performance.

They are especially effective for:

- lightweight powders,
- instantized proteins,
- specialty food ingredients,
- and advanced functional materials.



## VERTICAL VACUUM MIXERS & DRYERS

Vertical systems are often selected when:

- gentle processing,
  - reduced footprint,
  - controlled vertical flow,
  - or superior discharge characteristics
- ...are desired.



# 17

## VERTICAL PADDLE VACUUM MIXERS & DRYERS

# 18

These systems create controlled upward and downward material movement while maintaining:

- efficient thermal transfer,
- broad vacuum exposure,
- and highly uniform processing conditions.

They are ideal for:

- pharmaceuticals,
- specialty foods,
- nutraceuticals,
- and advanced materials.

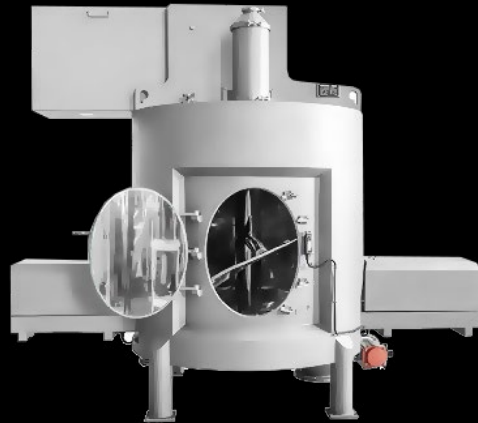

## VERTICAL VACUUM RIBBON MIXERS & DRYERS

# 19

QuantumX Vertical Vacuum Ribbon Mixers & Dryers combine vertical convective flow with low-shear thermal processing.

Their geometry allows excellent handling of:

- fragile powders,
- cohesive materials,
- and temperature-sensitive products.

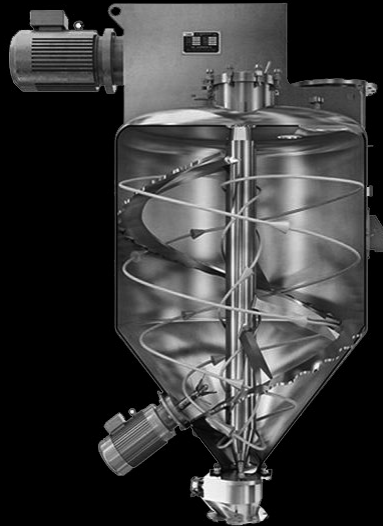

## VERTICAL VACUUM CONICAL MIXERS & DRYERS

# 20

Among the most advanced systems in the QuantumX portfolio, Vertical Vacuum Conical Mixers & Dryers are engineered for ultra-gentle, highly precise processing.

Their conical geometry promotes:

- complete discharge,
- low-energy mixing,
- minimal particle damage,
- and exceptional thermal uniformity.

These systems are widely used in:

- pharmaceuticals,
- nanotechnology,
- battery materials,
- and specialty chemicals.



## TUMBLE VACUUM MIXERS & DRYERS

Tumble systems are designed for extremely gentle processing environments where low-shear movement and particle preservation are critical.



# 21

---

## DOUBLE CONE VACUUM MIXERS & DRYERS

QuantumX Double Cone Vacuum Mixers & Dryers combine gentle tumbling action with efficient vacuum-assisted drying capability.

**These systems are ideal for:**

- fragile granules,
- pharmaceutical blends,
- specialty powders,
- and highly sensitive formulations.

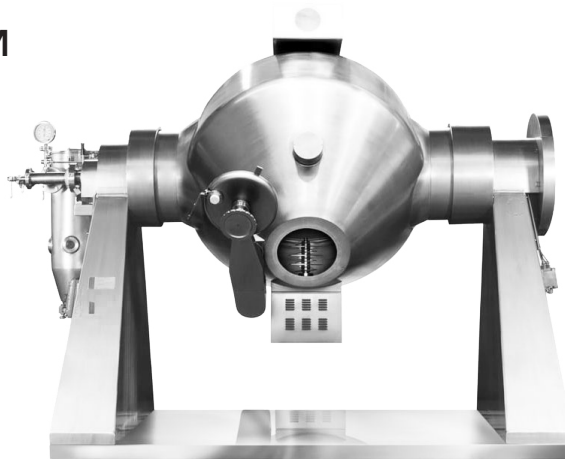

# 22

---

## VACUUM V-BLENDER MIXERS & DRYERS

QuantumX Vacuum V-Blenders & Dryers are designed for precision blending and highly controlled low-shear processing.

Their geometric tumbling action promotes exceptional blend uniformity while protecting delicate particle structures throughout the process cycle.



# 23

# APPLICATIONS – ENGINEERED FOR THE WORLD'S MOST DEMANDING MATERIALS

QuantumX Vacuum Mixers & Dryers are designed for manufacturers operating where process precision directly influences product quality, performance, and market value.

## APPLICATIONS INCLUDE:



### Pharmaceutical Processing

- Wet granulation
- API blending
- Vacuum drying
- OEB containment applications
- Controlled atmosphere processing



### Nutraceutical & Protein Systems

- Protein instantization
- Agglomeration
- Functional powder conditioning
- Heat-sensitive drying



### Food Processing

- Cocoa alkalization
- Flavor systems
- Nutritional powders
- Functional ingredient conditioning



### Specialty Chemicals

- Reactive powder processing
- Thermal modification
- Solvent removal
- Controlled atmosphere reactions



### Battery & Energy Materials

- Cathode/anode processing
- Conductive additive blending
- Moisture-sensitive material handling
- Advanced powder conditioning



### Cosmetics & Personal Care

- Functional powders
- Vacuum deaeration
- Specialty ingredient blending
- Thermal conditioning

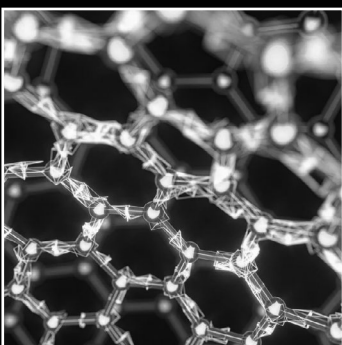

### Advanced Materials & Nanotechnology

- Carbon materials
- Ceramic powders
- Nanomaterial processing
- High-temperature transformation systems

# WE ARE YOUR ANSWER

The future of advanced manufacturing belongs to companies capable of controlling process environments—not simply operating equipment.

- Vacuum.
- Pressure.
- Thermal energy.
- Particle behavior.
- Moisture migration.
- Atmosphere control.
- Granulation.
- Drying.
- Transformation.

**These are no longer isolated process variables. They are part of a single engineered reality.**

QuantumX™ Vacuum Mixers & Dryers were built for manufacturers who demand more than machinery.

**They were built for manufacturers seeking:**

- process stability,
- repeatable performance,
- scalable production,
- thermal precision,
- particle control,
- and engineered certainty.

Not simply to mix materials. But to solve the processing challenges others cannot.

QuantumX™ —  
The Next Generation  
of Mixing.

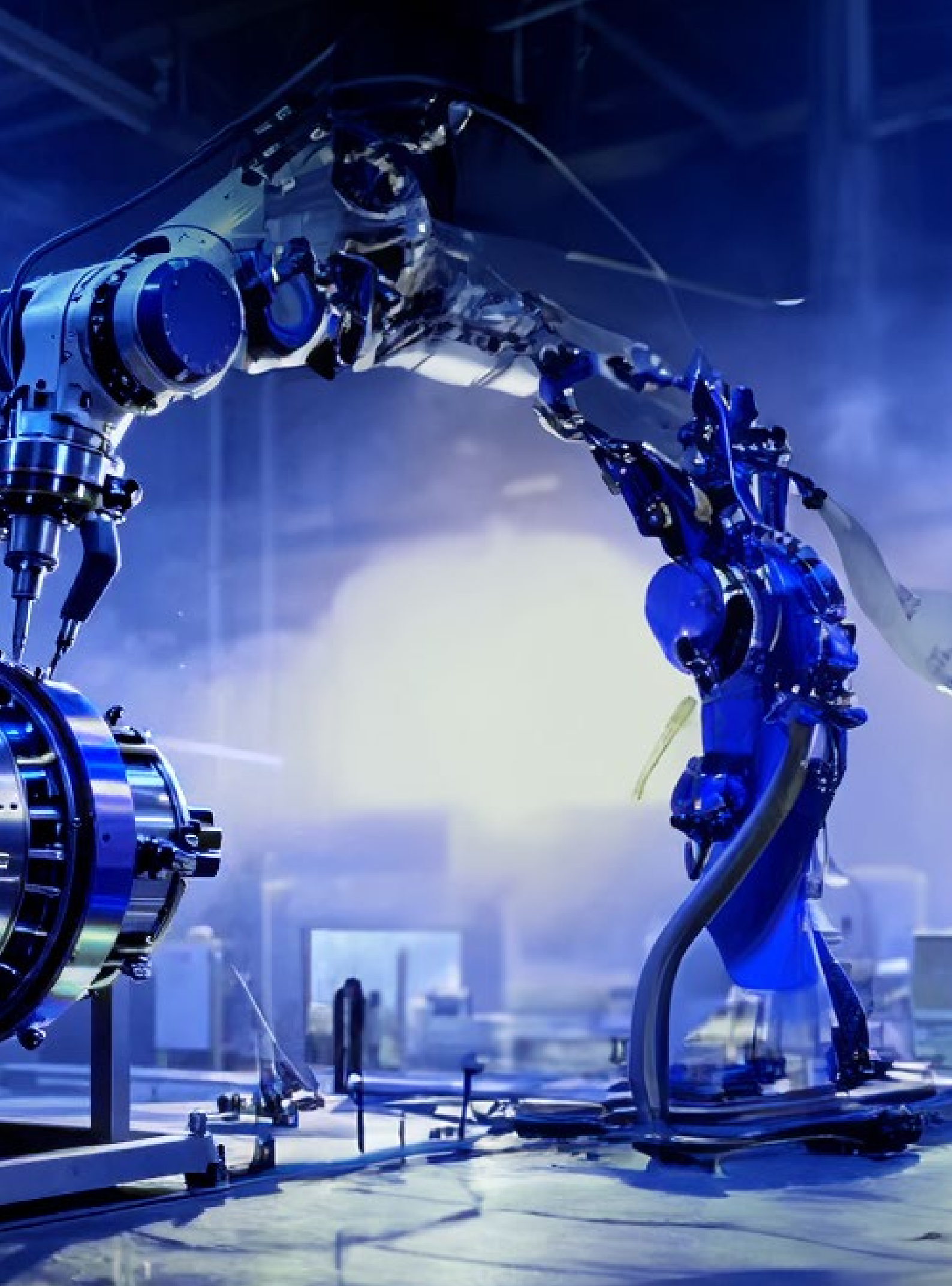



QuantumX